

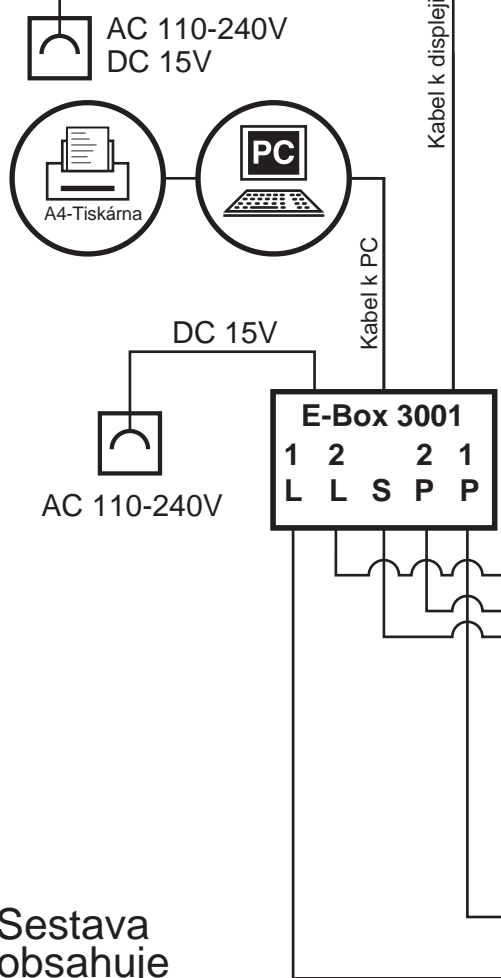

Displej V 360 x Š 800 x H 35

**Sestava obsahuje**

- 4 Brzdové segmenty
  - 2 Segmenty sbíhavosti
  - 1 Sada montážních rámu
  - 1 E-Box 3001 řídicí elektronika
  - 1 Kabel 220V k E-Box
  - 5 Sensorový kabel á 15 m
  - 1 Kabel k PC 13 m
  - 1 Program na CD
  - 1 Radiové dálk.ovládání
  - 1 Instal. sada - šrouby a hmoždinky
- 
- 1 Displej
  - 1 Kabel k displeji 20 m
  - 1 Kabel 220 V k displeji
  - 1 Závesný profil 1 m

